

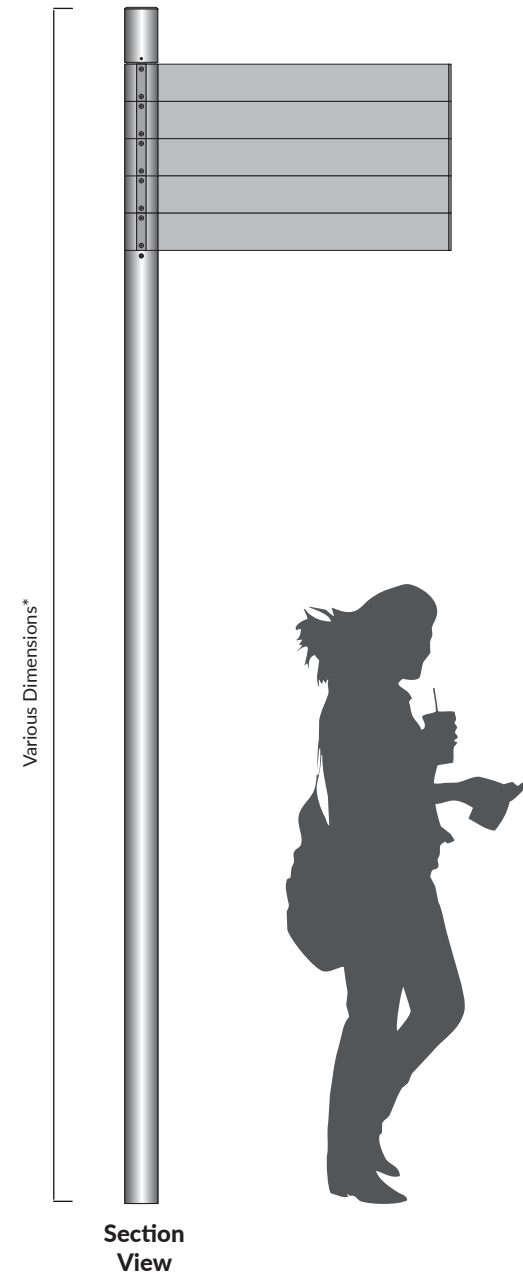

PROFILES

STANDARD DESIGN



HERITAGE DESIGN*

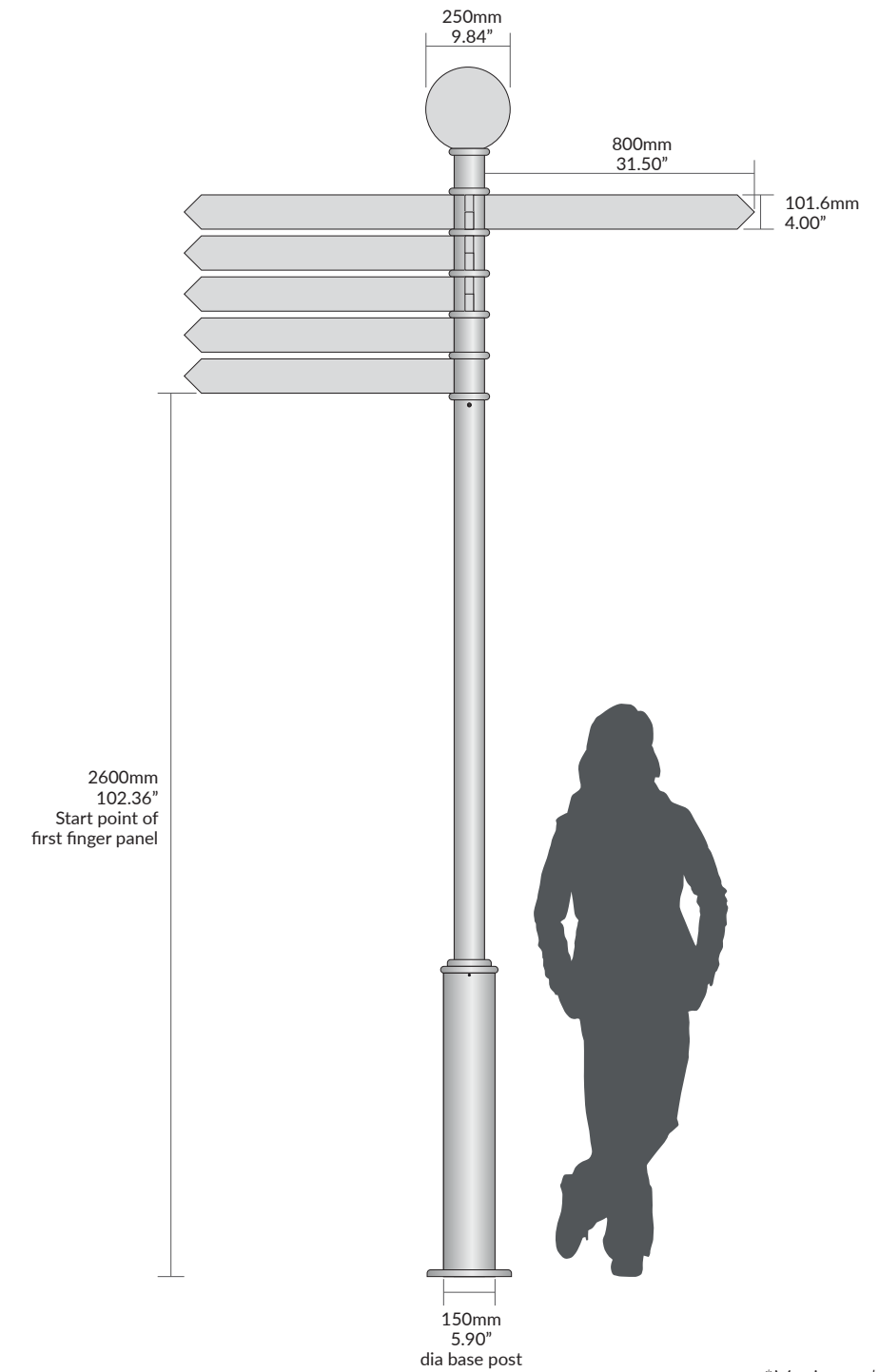

*Maximum height 3.1mtrs or 10.17 ft

*Heritage is made to order, contact distributor for an estimate

SPECS

STANDARD - SIGN FINGER ASSEMBLY

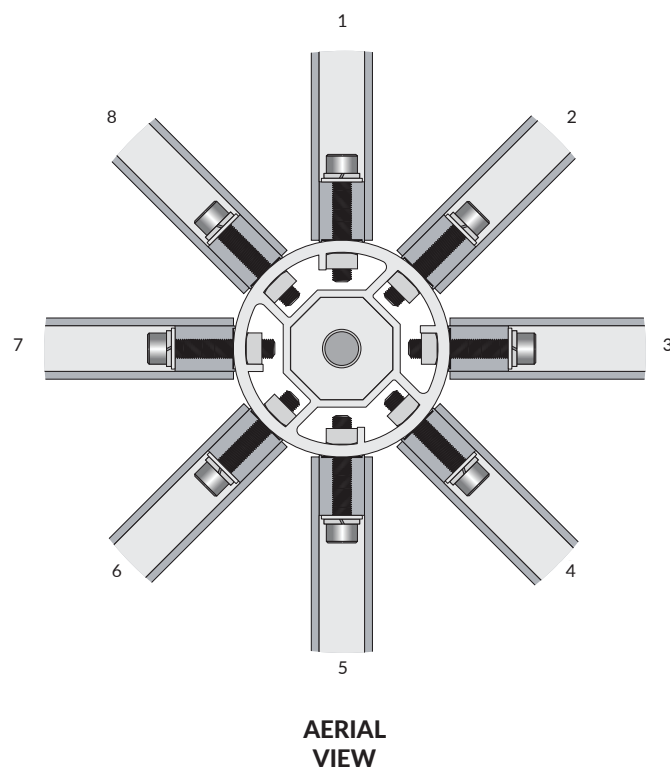

ENGINEERED FOR FLEXIBILITY

What makes OCTOPUS unique; is the octagonal telescopic spline that holds the collars in position. This can be raised or lowered to add or remove collars, without re-engineering on site. No more posts with redundant holes or drilling on site or obvious extensions or squeezing additional fingers onto existing collars. OCTOPUS posts, collars and finials are supplied finished in self-healing anodized aluminum as standard and can be painted or polyester powder coated in any MATTHEWS PAINT or PMS Pantone color.

- 8 DIFFERENT DIRECTIONS**
- 5 FINGERS TALL**
- 40 DIRECTION POSSIBILITIES**

OCTOPUS

OCTOPUS represents a new generation of fingerpost system. Like CHAMELEON, its stable companion, OCTOPUS can be dressed up or pared down to fit into any environment. OCTOPUS is an engineered product, constructed from robust aluminum extrusions. OCTOPUS has eight fixing positions on each collar and five collars can be stacked on top of each other. This makes OCTOPUS more than flexible enough to meet any urban or campus wayfinding requirements.

HERITAGE - SIGN FINGER ASSEMBLY

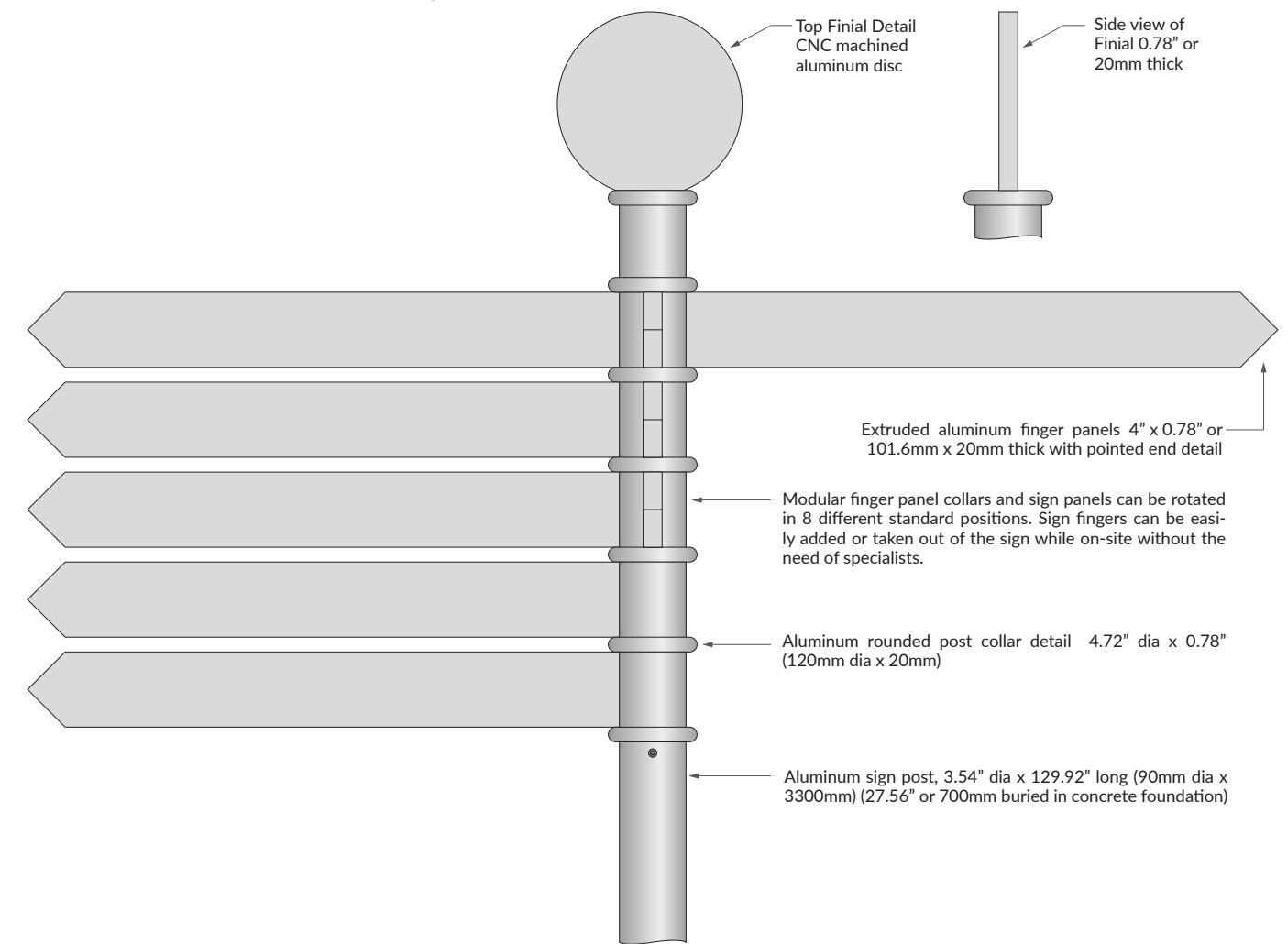

SPECS

SIGN FINGER AND FINIAL ASSEMBLY

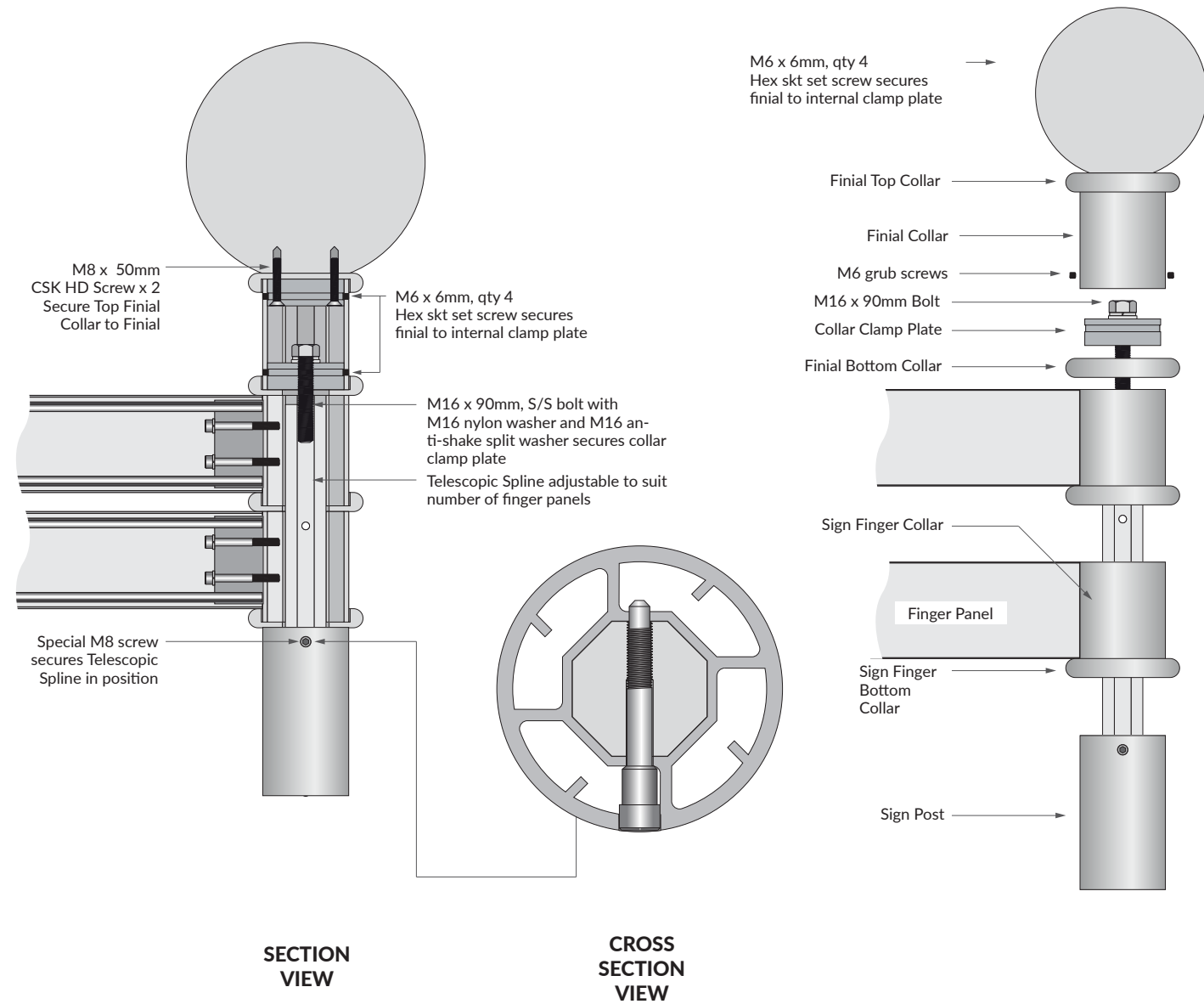

MOUNTING OPTIONS

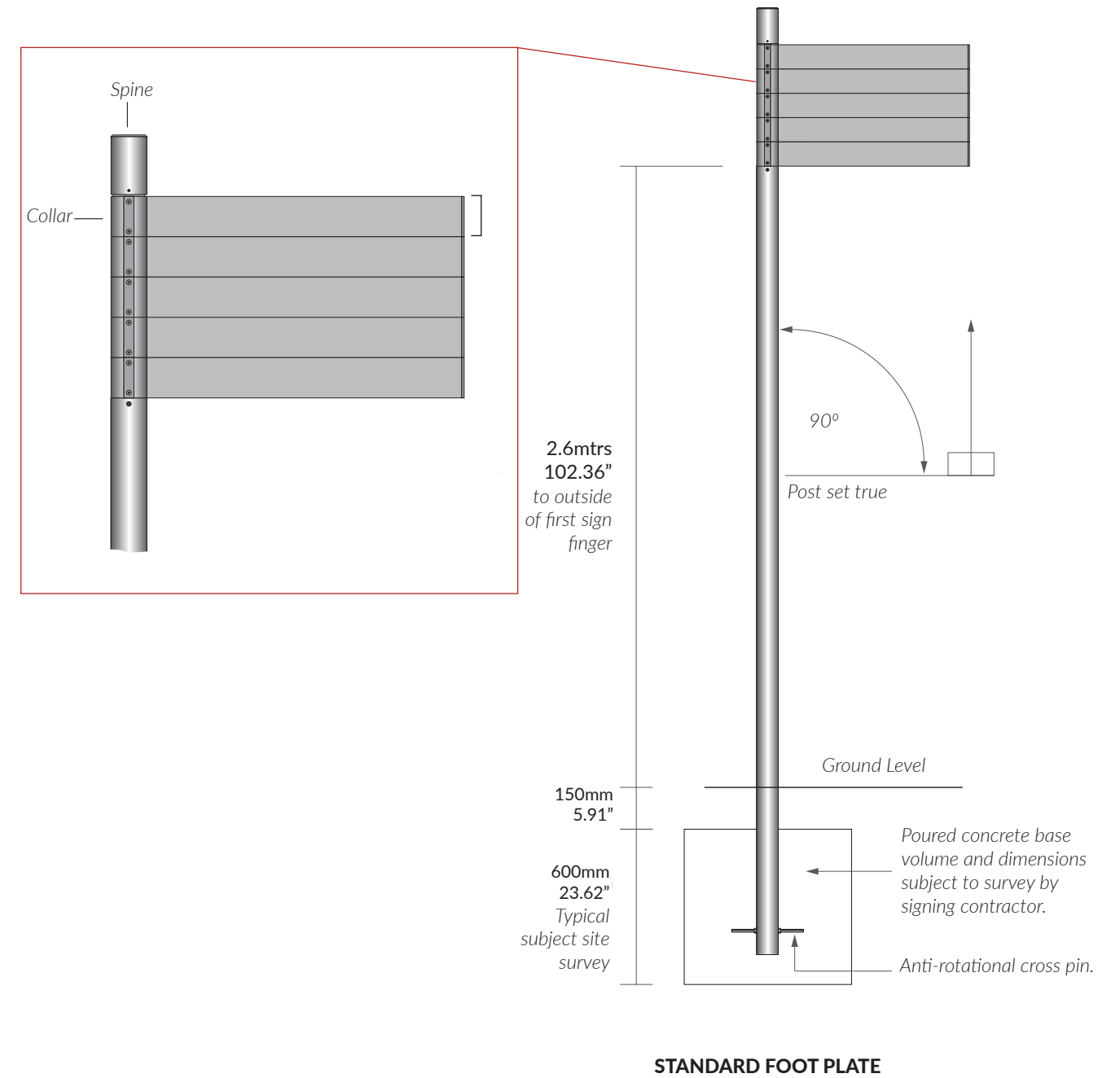



FINISHES

FINISHING OPTIONS



CUSTOMIZATION

OCTOPUS fingers are very strong box section extrusions, that can be painted or polyester powder coated in any MATTHEWS PAINT color. Graphics can be CNC cut vinyl, silkscreen printed or direct to media digital prints. OCTOPUS comes fitted with cross studs as standard, to set into a concrete footing. A footplate is also available to allow the sign to fit onto a root cage or chemical anchor bolts.

SOLUTIONS

OCTOPUS is suitable for many projects ranging from;

- Town centers,
- Business parks,
- Hospital or university campuses,
- Anywhere pedestrians need directions

OCTOPUS is designed to compliment the CHAMELEON monolith system to provide a complete wayfinding solution for the outside world.